

# VESTING TENTATIVE MAP BELLA VISTA SUBDIVISION

## LYING WITHIN THE UNINCORPORATED AREA OF MENDOCINO COUNTY, CALIFORNIA

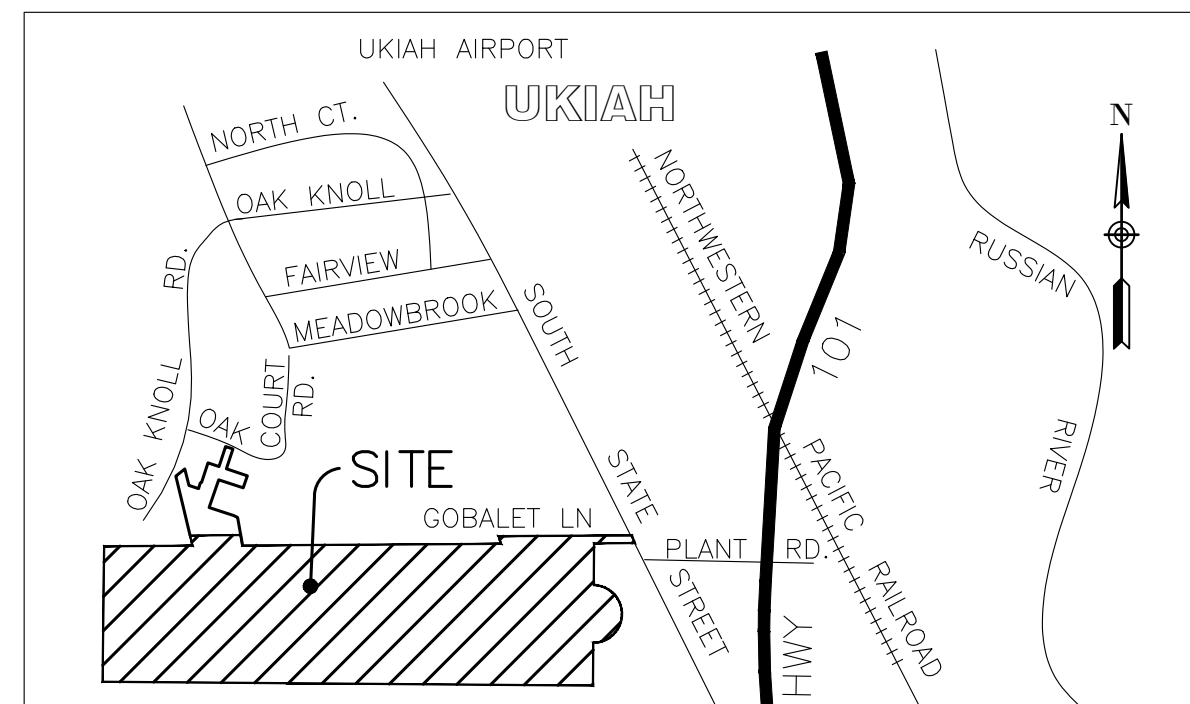

**VICINITY MAP**  
N.T.S

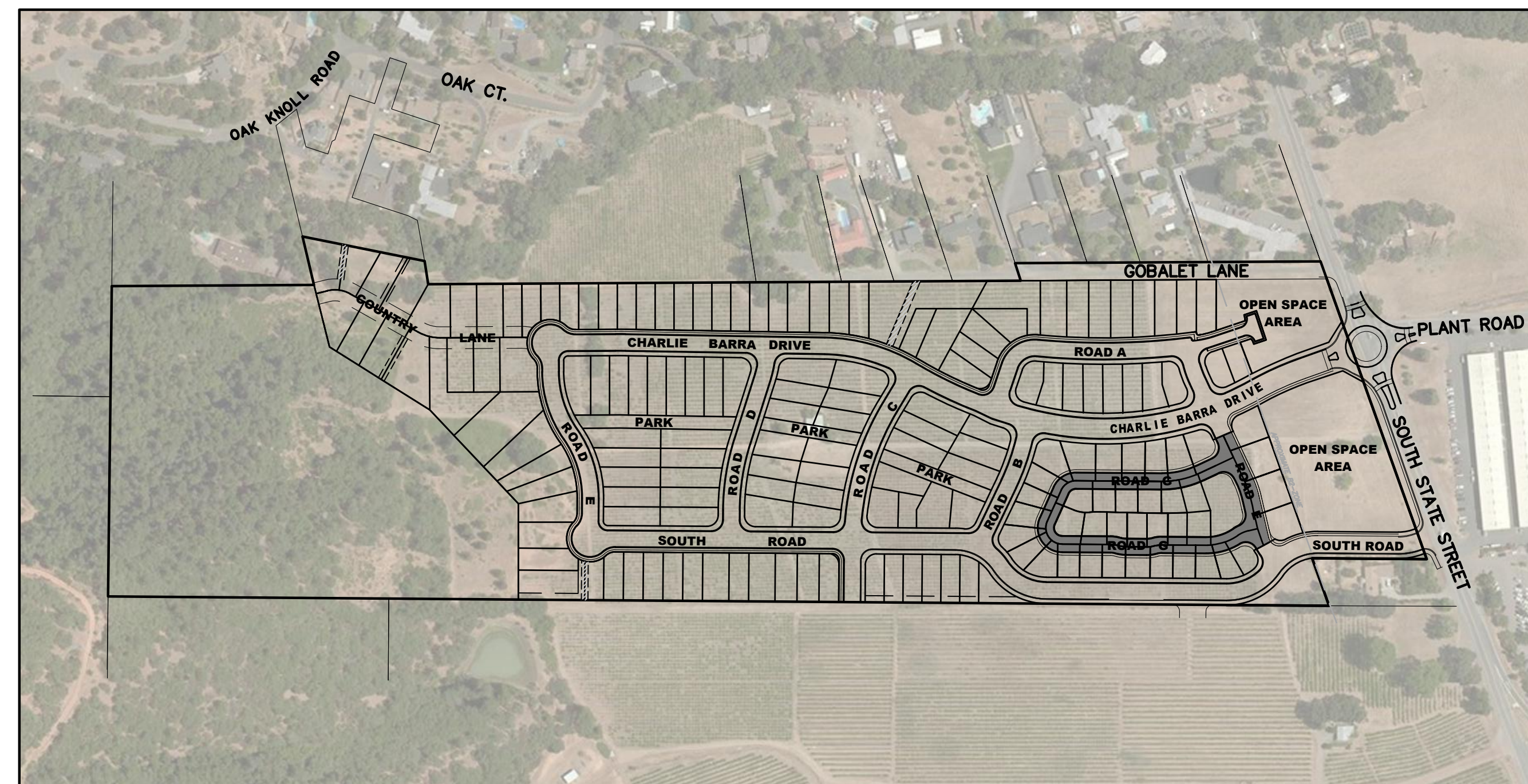

**PROJECT DATA**

PROPERTY ADDRESS: 3000 S STATE STREET,  
UKIAH, CA 95482

PROPERTY OWNER:  
YOKAYO RANCH LP.  
800 HENSLEY CREEK RD  
UKIAH, CA 95482

SURVEYOR/CIVIL ENGINEER:  
LACO ASSOCIATES  
776 S. STATE ST.,  
SUITE 102A  
UKIAH, CA 95482

EXISTING LAND USE: VINEYARD

EXISTING ZONING: SR, RR-5, AZ-B2,  
AZ-C, AZ-D

PROPOSED ZONING: SUBURBAN RESIDENTIAL

NUMBER OF LOTS: 171

PARKS & OPEN SPACE AREA SIZE: 4.39  
ACRES

MINIMUM GROSS LOT SIZE: 3,479  
SQUARE FEET

MAXIMUM GROSS LOT SIZE: 18,088  
SQUARE FEET

EXISTING ACREAGE: 48.8 ACRES

APN: 184-110-28, 184-110-29,  
148-120-21 & 184-120-01

**LEGEND/ABBREVIATIONS**

- PROPOSED PARCEL LINE
- EXISTING BOUNDARY LINE
- - - - PROPOSED WATER MAIN EASEMENT
- - - - ROAD CENTERLINE
- PHASE LINE
- WV (in square) WATER VALVE
- FD (in circle) FIRE HYDRANT
- S (in circle) SANITARY SEWER MANHOLE
- STORM DRAIN
- DROP INLET
- JT— JOINT TRENCH
- ▭ CURB INLET
- - - - BUILDING SETBACK LINE (BSL)
- ⌚ PROPERTY LINE

**SHEET INDEX**

- 1 COVER SHEET
- 2 EXISTING PARCEL MAP
- 3 PHASING LAYOUT
- 4 PARCEL LAYOUT
- 5 PARCEL LAYOUT SENIOR AREA
- 6 GRADING & DRAINAGE
- 7 GRADING & DRAINAGE
- 8 UTILITIES AND IMPROVEMENTS
- 9 UTILITIES AND IMPROVEMENTS
- 10 ROAD SECTION DETAILS

**SURVEYOR**

PREPARED UNDER THE SUPERVISION OF:  
  
BRADLEY A. THOMAS PLS 5520 8/31/2020  
DATE DATE

**OWNER/SUBDIVIDER**

THIS MAP HAS BEEN APPROVED BY:  
  
DOUGLAS GULLON X/XX/XXXX  
OWNER/SUBDIVIDER DATE

**NOTES**

BOUNDARY LINES / LOT LINES SHOWN ON THIS MAP DERIVED FROM FOUND MONUMENTS AND RECORD DATA

NO.	HISTORY / REVISION	BY	CHK.	DATE
1	ADDRESS COUNTY COMMENTS	X	X	8/28/2020

VESTING TENTATIVE MAP  
GULLON INC. CONSTRUCTION  
3000 S STATE STREET, UKIAH, CA 95482

**COVER SHEET**

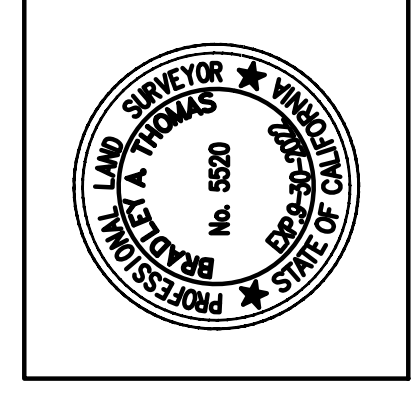

DRAWN	AR
CHECK	CCM
APPROVED	KD
DATE	August 30, 2022
JOB NUMBER	9100.06
DRAWING	

**LACO**

EUREKA • UKIAH • SANTA ROSA • CHICO  
1-800-515-5054 www.lacoassociates.com



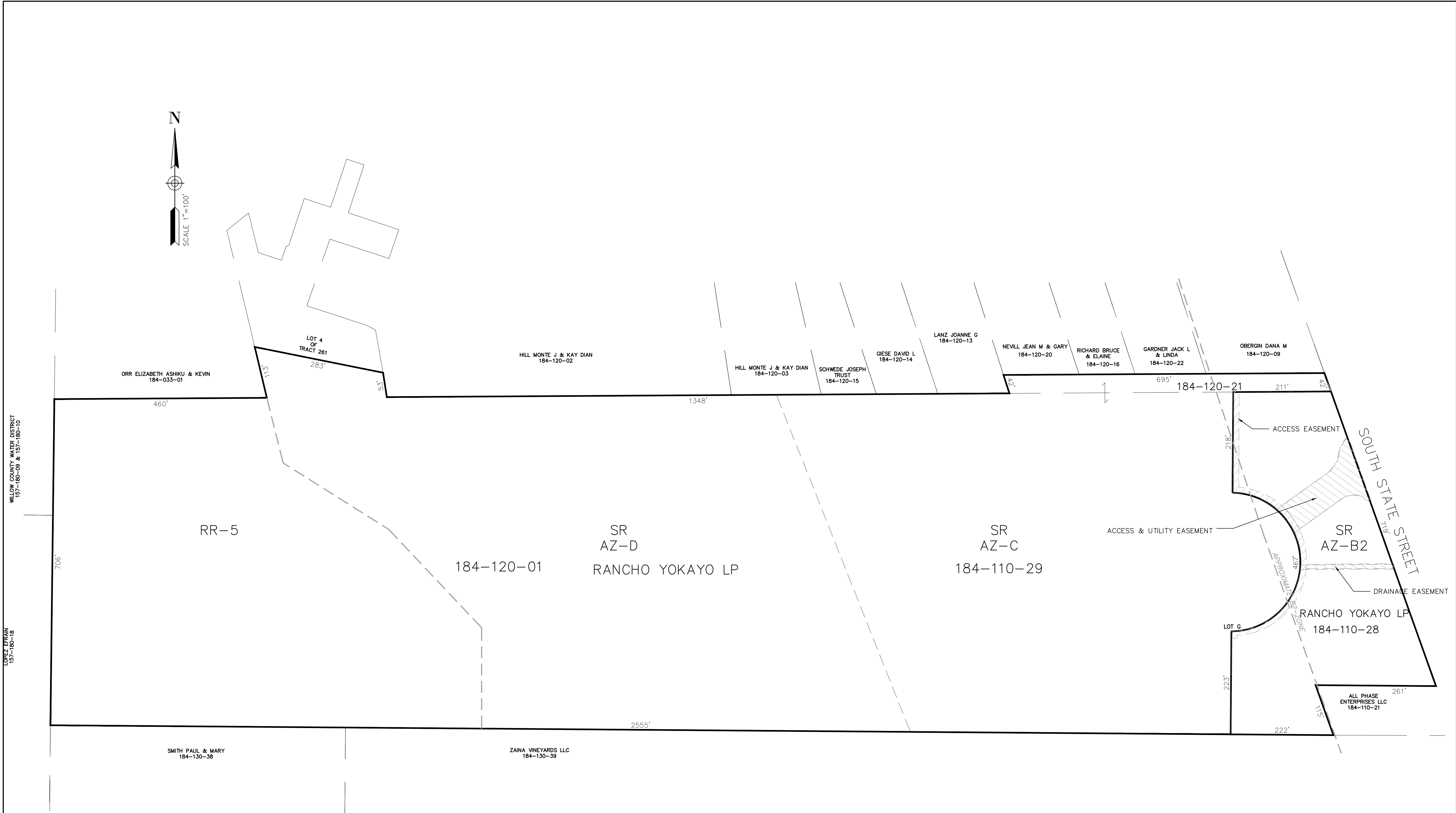
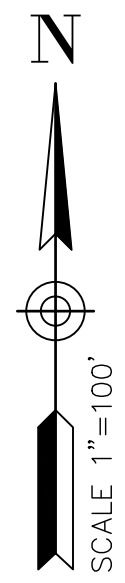

LEGEND



EXISTING EASEMENT TO BE ABANDONED WITH THE RECORDATION OF PHASE 1.

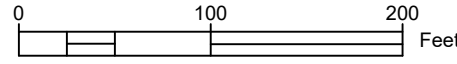

LACO  
 EUREKA • UKIAH • SANTA ROSA • CHICO  
 1-800-515-5054  
 www.lacoassociates.com

NO.	HISTORY / REVISION	BY / CHK	DATE
1	ADDRESS COUNTY COMMENTS	X	8/28/2020

VESTING TENTATIVE MAP  
 GULLON INC. CONSTRUCTION  
 3000 S STATE STREET, UKIAH, CA 95482  
 EXISTING PARCEL MAP

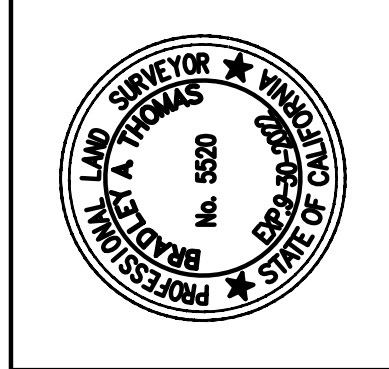

DRAWN	AR
CHECK	CCM
APPROVED	KD
DATE	August 31, 2022
JOB NUMBER	9100.06
DRAWING	

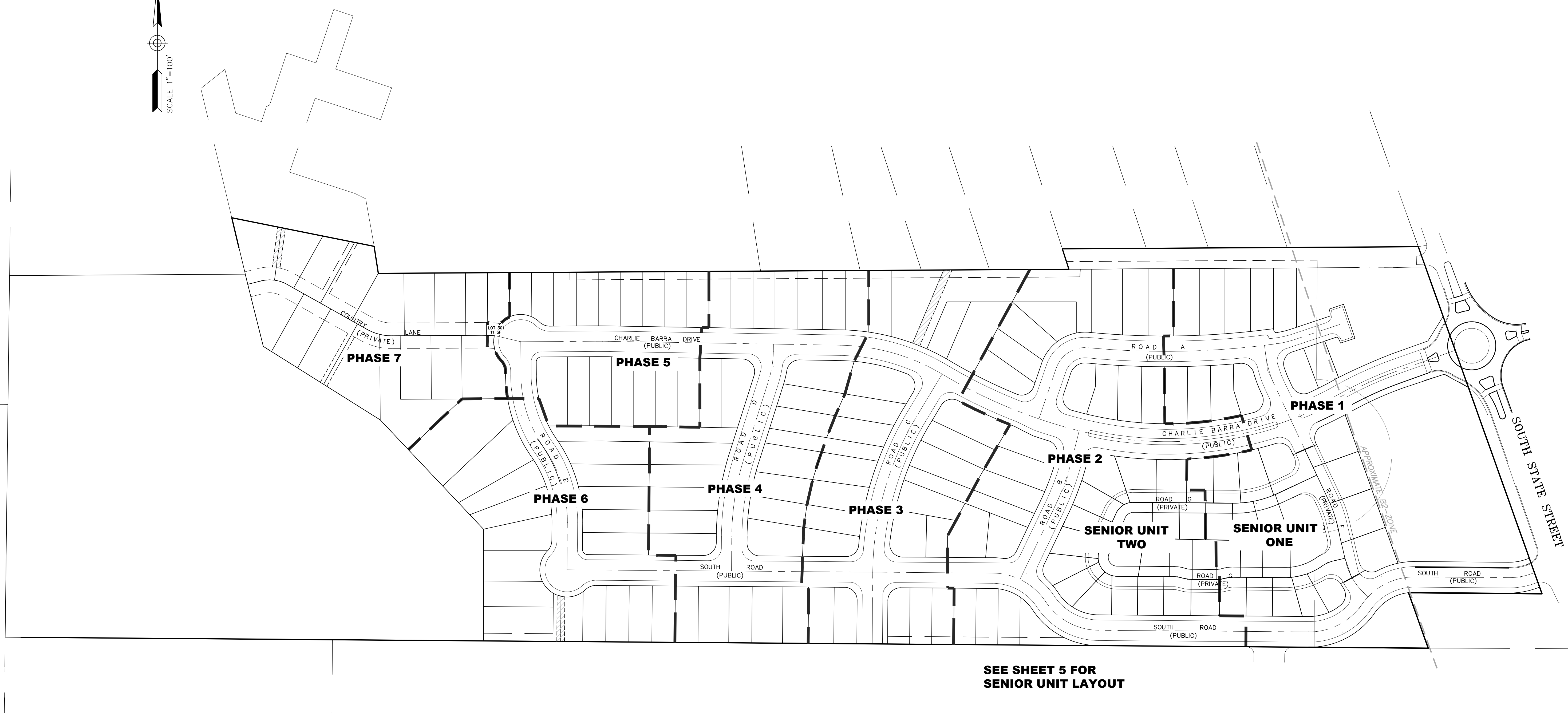
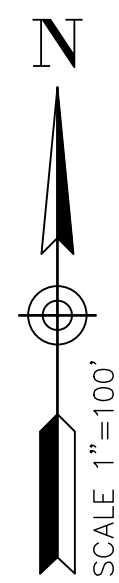

PHASING	
PHASE NUMBER	NUMBER OF LOTS
1	11
2	21
3	23
4	26
5	16
6	18
7	17

SENIOR AREA PHASING	
PHASE NUMBER	NUMBER OF LOTS
1	19
2	20

NOTE: PHASING LAYOUT MAY BE MODIFIED PURSUANT TO THE DEVELOPMENT AGREEMENT

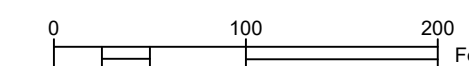

NO.	HISTORY / REVISION	BY	CHK.	DATE
1	ADDRESS COUNTY COMMENTS	X	X	8/28/2020

VESTING TENTATIVE MAP  
 GUILLON INC. CONSTRUCTION  
 3000 S STATE STREET, UKIAH, CA 95482

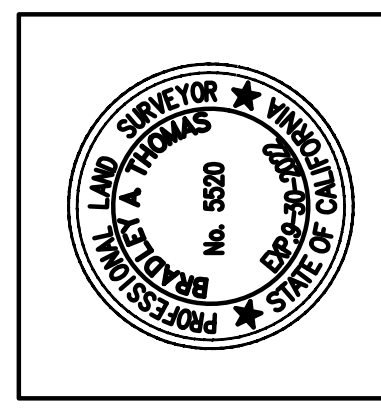

DRAWN	AR
CHECK	CCM
APPROVED	KD
DATE	August 31, 2022
JOB NUMBER	9100.06
DRAWING	

3/10

LACO  
 EUREKA • UKIAH • SANTA ROSA • CHICO  
 1-800-515-5054 www.lacoassociates.com

SUBDIVISION PHASING



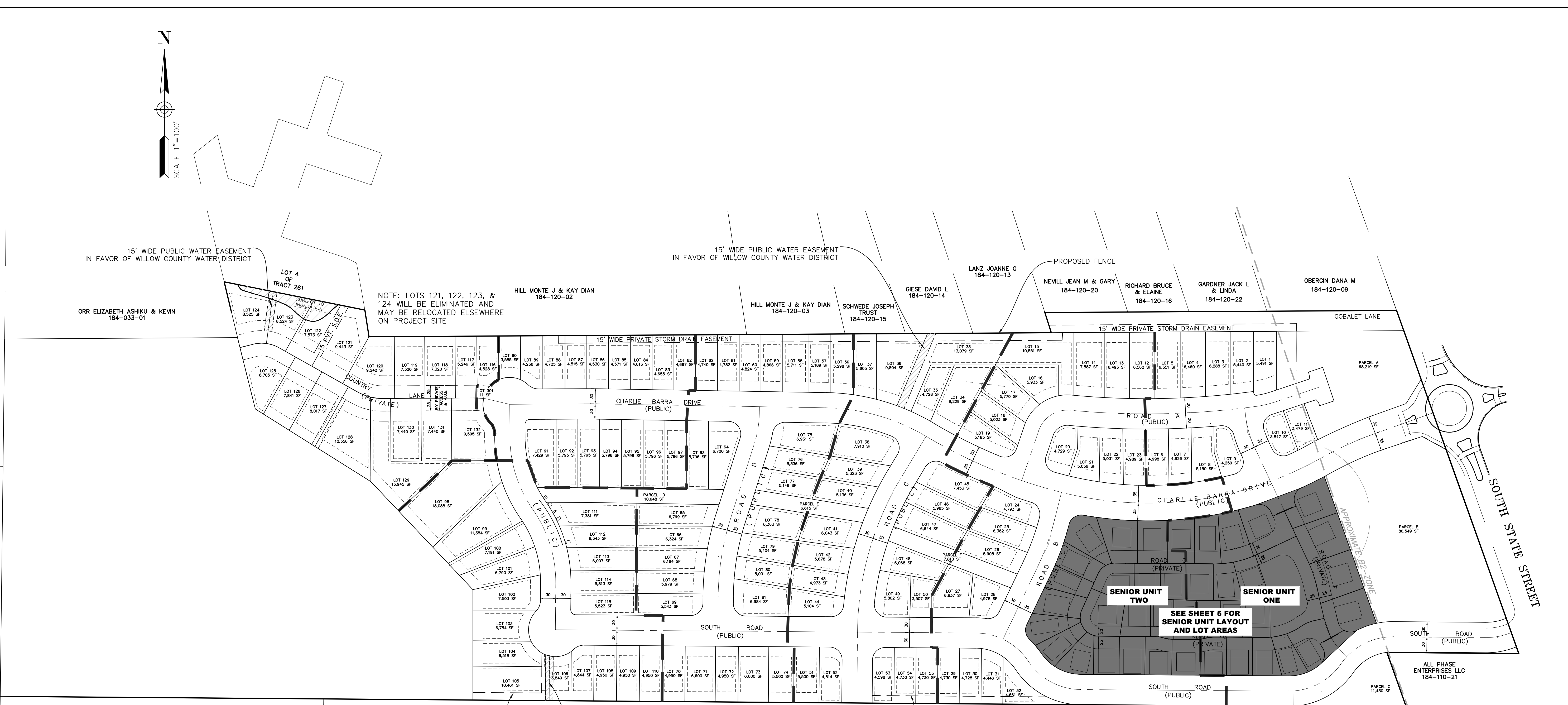
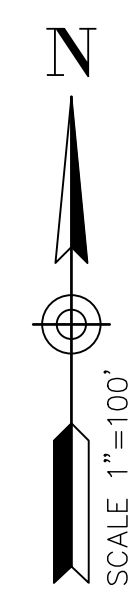

LOT NUMBER	AREA (GROSS)	AREA (NET)
LOT 1	5,491	5,491
LOT 2	5,440	5,440
LOT 3	6,288	6,288
LOT 4	6,460	6,460
LOT 5	6,551	6,551
LOT 6	4,998	4,998
LOT 7	4,926	4,926
LOT 8	5,150	5,150
LOT 9	4,259	4,259
LOT 10	3,847	3,847
LOT 11	3,479	3,479
LOT 12	6,562	6,562
LOT 13	6,493	6,493
LOT 14	7,587	7,587
LOT 15	10,551	9,019
LOT 16	5,933	5,933
LOT 17	5,770	5,770
LOT 18	5,023	5,023
LOT 19	5,185	5,185
LOT 20	4,729	4,729

LOT NUMBER	AREA (GROSS)	AREA (NET)
LOT 21	5,056	5,056
LOT 22	5,031	5,031
LOT 23	4,989	4,989
LOT 24	4,793	4,793
LOT 25	6,382	6,382
LOT 26	5,908	5,908
LOT 27	6,837	6,837
LOT 28	4,978	4,978
LOT 29	4,730	4,085
LOT 30	4,728	4,083
LOT 31	4,446	3,801
LOT 32	4,661	3,032
LOT 33	13,079	8,445
LOT 34	9,229	9,229
LOT 35	4,728	4,728
LOT 36	9,804	8,335
LOT 37	5,605	4,930
LOT 38	7,910	7,910
LOT 39	5,323	5,323
LOT 40	5,136	5,136

LOT NUMBER	AREA (GROSS)	AREA (NET)
LOT 41	6,043	6,043
LOT 42	5,678	5,678
LOT 43	4,973	4,973
LOT 44	5,104	5,104
LOT 45	7,453	7,453
LOT 46	5,985	5,985
LOT 47	6,644	6,644
LOT 48	6,068	6,068
LOT 49	5,802	5,802
LOT 50	3,507	3,507
LOT 51	5,500	5,500
LOT 52	4,814	4,814
LOT 53	4,598	3,952
LOT 54	4,730	4,085
LOT 55	4,730	4,085
LOT 56	5,298	4,623
LOT 57	5,189	4,514
LOT 58	5,711	4,961
LOT 59	4,866	4,221
LOT 60	4,824	4,179

LOT NUMBER	AREA (GROSS)	AREA (NET)
LOT 61	4,782	4,137
LOT 62	4,740	4,095
LOT 63	5,796	5,796
LOT 64	6,700	6,700
LOT 65	6,799	6,799
LOT 66	6,324	6,324
LOT 67	6,164	6,164
LOT 68	5,979	5,979
LOT 69	5,543	5,543
LOT 70	4,950	4,950
LOT 71	6,600	6,600
LOT 72	4,950	4,950
LOT 73	6,600	6,600
LOT 74	5,500	5,500
LOT 75	6,931	6,931
LOT 76	5,336	5,336
LOT 77	5,149	5,149
LOT 78	6,363	6,363
LOT 79	5,404	5,404
LOT 80	5,001	5,001

LOT NUMBER	AREA (GROSS)	AREA (NET)
LOT 81	6,984	6,984
LOT 82	4,697	4,052
LOT 83	4,655	4,010
LOT 84	4,613	3,968
LOT 85	4,571	3,926
LOT 86	4,530	3,885
LOT 87	4,515	3,870
LOT 88	4,725	4,527
LOT 89	4,238	4,238
LOT 90	3,585	3,585
LOT 91	7,429	7,429
LOT 92	5,795	5,795
LOT 93	5,795	5,795
LOT 94	5,796	5,796
LOT 95	5,796	5,796
LOT 96	5,796	5,796
LOT 97	5,796	5,796
LOT 98	18,088	18,088
LOT 99	11,384	11,384
LOT 100	7,191	7,191

LOT NUMBER	AREA (GROSS)	AREA (NET)
LOT 101	6,790	6,790
LOT 102	7,503	7,503
LOT 103	6,754	6,754
LOT 104	6,518	6,518
LOT 105	10,461	7,067
LOT 106	4,530	3,194
LOT 107	4,844	4,844
LOT 108	4,950	4,950
LOT 109	4,950	4,950
LOT 110	4,950	4,950
LOT 111	7,381	7,381
LOT 112	6,343	6,343
LOT 113	6,007	6,007
LOT 114	5,813	5,813
LOT 115	5,523	5,523
LOT 116	4,528	4,105
LOT 117	5,246	4,171
LOT 118	7,320	5,820
LOT 119	7,320	5,820
LOT 120	9,243	6,674

LOT NUMBER	AREA (GROSS)	AREA (NET)
LOT 121	9,443	7,032
LOT 122	7,573	5,079
LOT 123	6,524	4,801
LOT 124	8,525	6,491
LOT 125	8,705	6,020
LOT 126	7,841	6,341
LOT 127	8,017	6,517
LOT 128	12,356	10,994
LOT 129	13,945	12,940
LOT 130	7,440	5,940
LOT 131	7,440	5,940
LOT 132	9,595	8,019

PARCEL	AREA
PARCEL A	68,219
PARCEL B	86,549
PARCEL C	11,430
TOTAL	166,198
LINEAR PARK AREA	
PARCEL D	10,648
PARCEL E	6,615
PARCEL F	7,810
TOTAL	25,073
OTHER AREAS	
DESCRIPTION	AREA
PUBLIC ROW	390,450
SENIOR HOA	194,751
COMMON PARCEL G	9763
REMAINDER	531,242

NO.	HISTORY / REVISION	BY	CHK.	DATE
1	ADDRESS COUNTY COMMENTS	X	X	8/28/2020

VESTING TENTATIVE MAP  
 GUILLON INC. CONSTRUCTION  
 3000 S STATE STREET, UKIAH, CA 95482

LOT LAYOUT

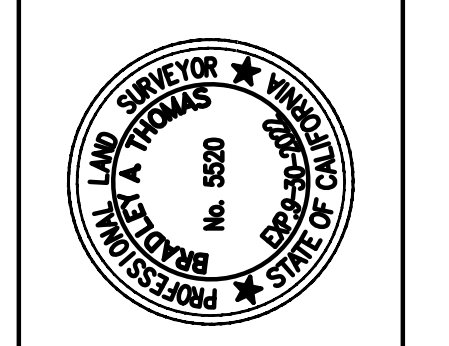

DRAWN	AR
CHECK	CCM
APPROVED	KD
DATE	August 31, 2022
JOB NUMBER	9100.02
DRAWING	4/10



NO.	HISTORY / REVISION	BY	CHK.	DATE
1	ADDRESS COUNTY COMMENTS	X	X	8/28/2020

VESTING TENTATIVE MAP  
 GUILLON INC. CONSTRUCTION  
 3000 S STATE STREET, UKIAH, CA 95482

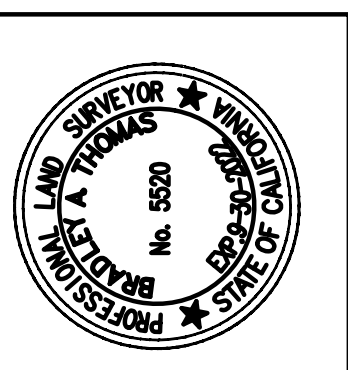

DRAWN	AR
CHECK	CCM
APPROVED	KD
DATE	August 31, 2022
JOB NUMBER	9100.06
DRAWING	

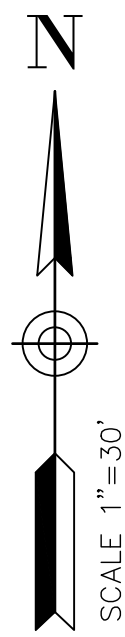

LEGEND

- RESTRICTED USE EASEMENT
- IE & PUE
- IE -INGRESS & EGRESS
- PUE -PUBLIC UTILITY EASEMENT
- EXCLUSIVE USE PARK EASEMENT

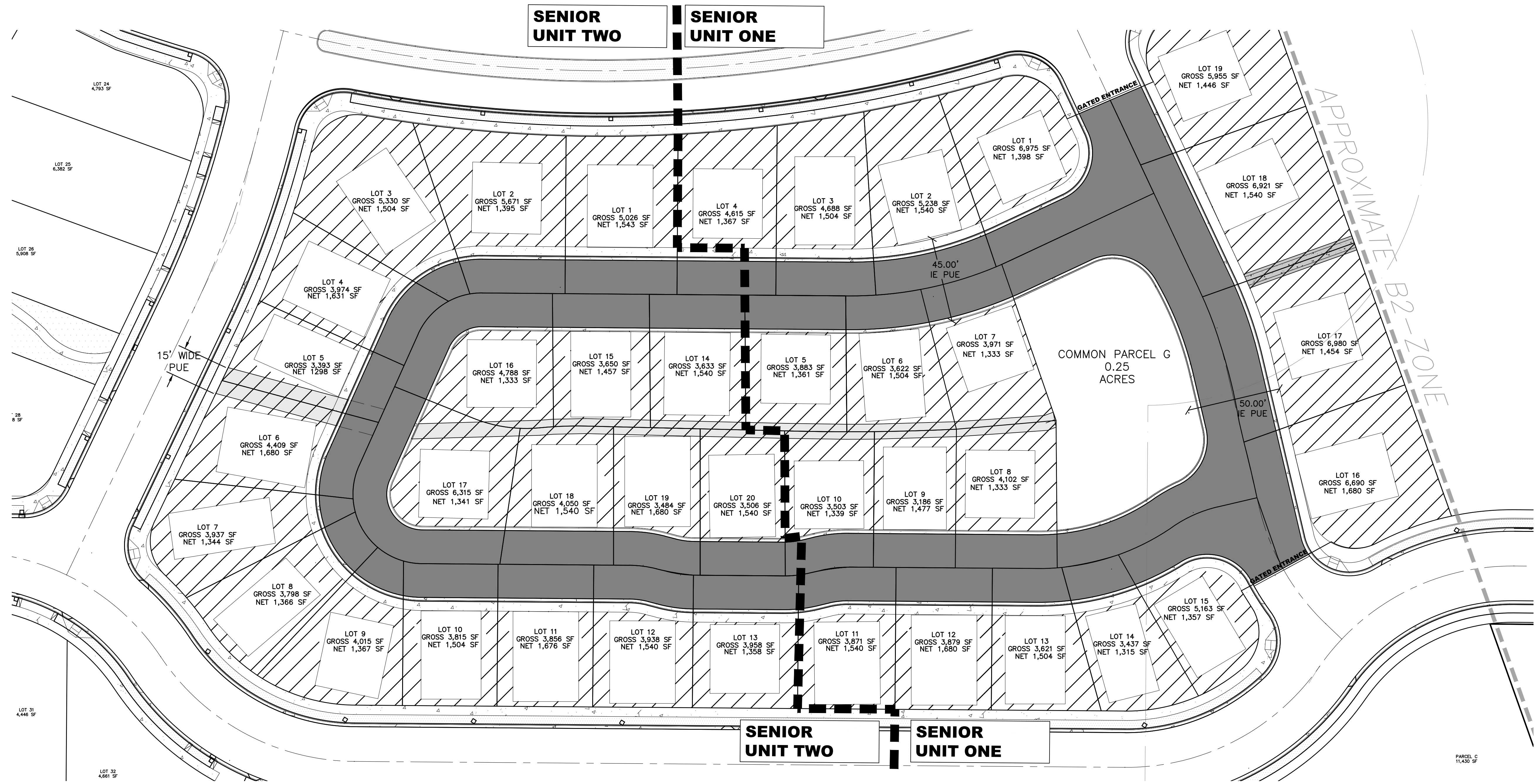



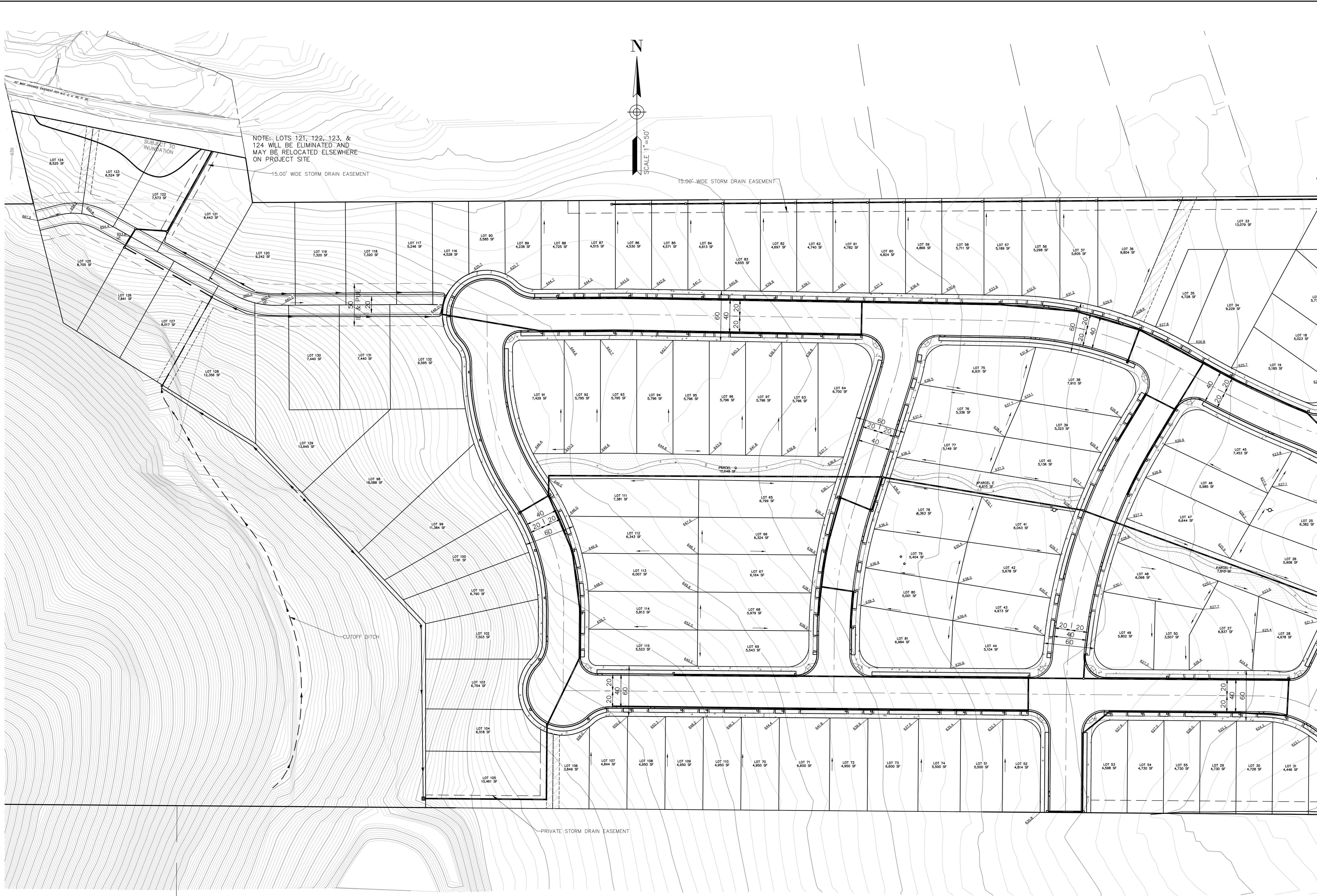

LACO

EUREKA • UKIAH • SANTA ROSA • CHICO

1-800-515-5054 www.lacoassociates.com

NO.	HISTORY / REVISION	BY	CHK.	DATE
1	ADDRESS COUNTY COMMENTS	X	X	8/28/2020

VESTING TENTATIVE MAP  
 GUILLON INC. CONSTRUCTION  
 3000 S STATE STREET, UKIAH, CA 95482

**GRADING & DRAINAGE**

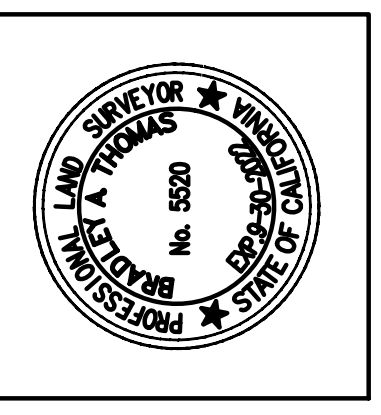

DRAWN	AR
CHECK	CCM
APPROVED	KD
DATE	August 31, 2022
JOB NUMBER	9100.06
DRAWING	



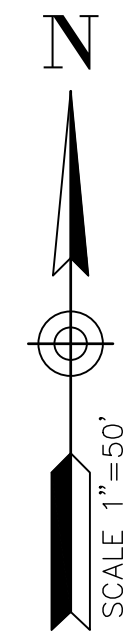
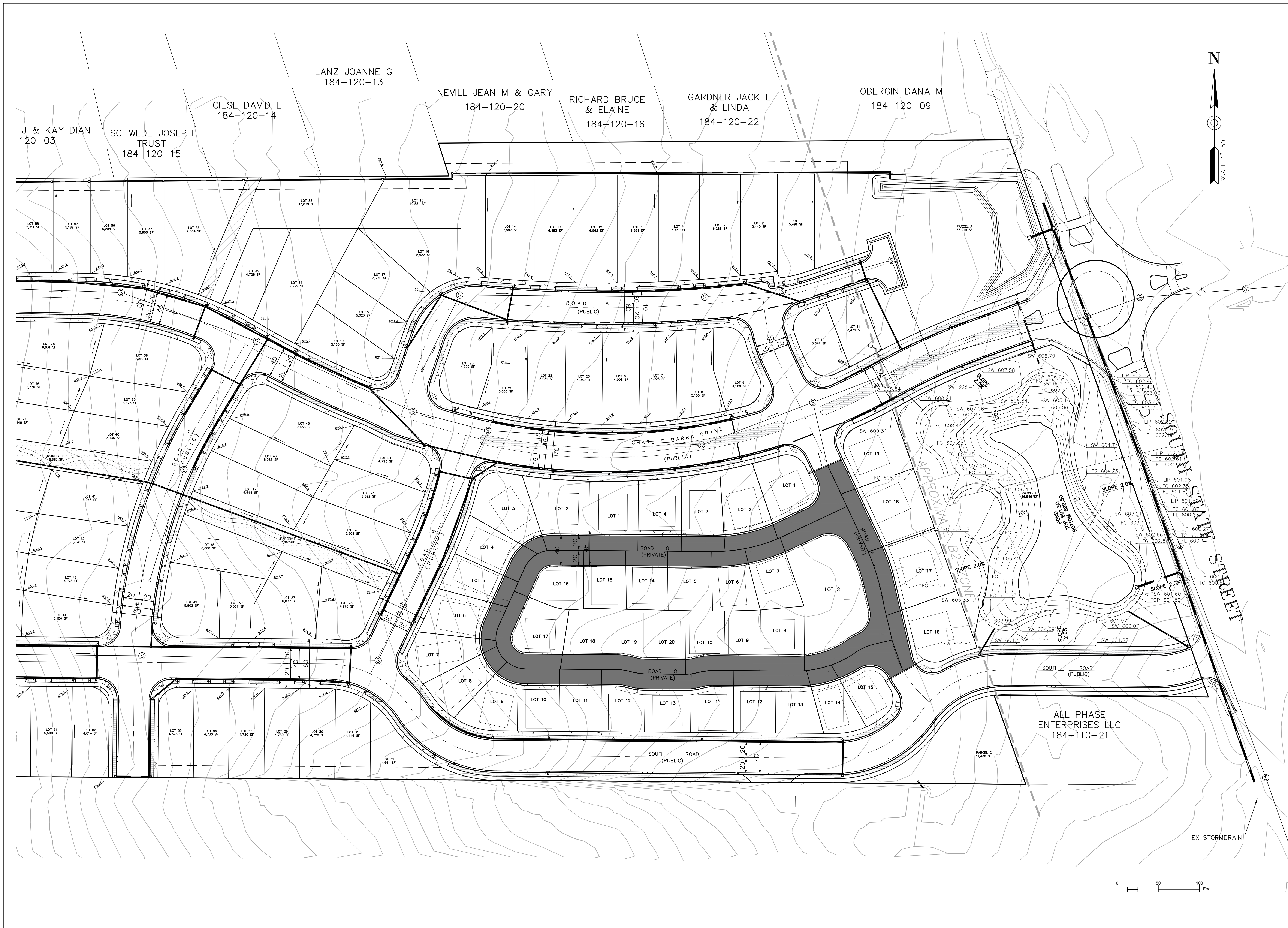

**LACO**  
 EUREKA • UKIAH • SANTA ROSA • CHICO  
 1-800-515-5054 www.lacoassociates.com

NO.	HISTORY / REVISION	BY	CHK.	DATE
1	ADDRESS COUNTY COMMENTS	X	X	8/28/2020

**VESTING TENTATIVE MAP**  
**GUILLON INC. CONSTRUCTION**  
 3000 S STATE STREET, UKIAH, CA 95482

**GRADING AND DRAINAGE**

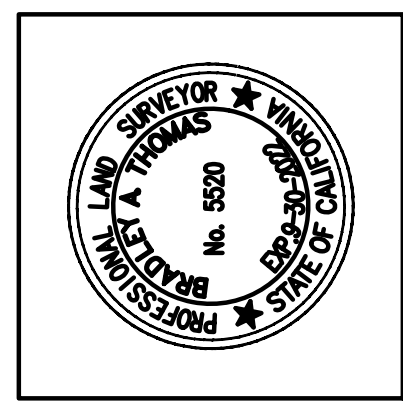

DRAWN	AR
CHECK	CCM
APPROVED	KD
DATE	August 31, 2022
JOB NUMBER	9100.06
DRAWING	7/10



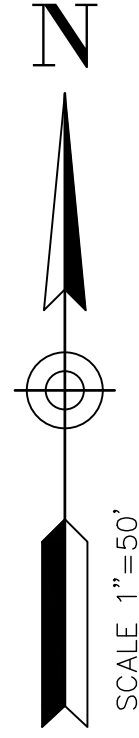
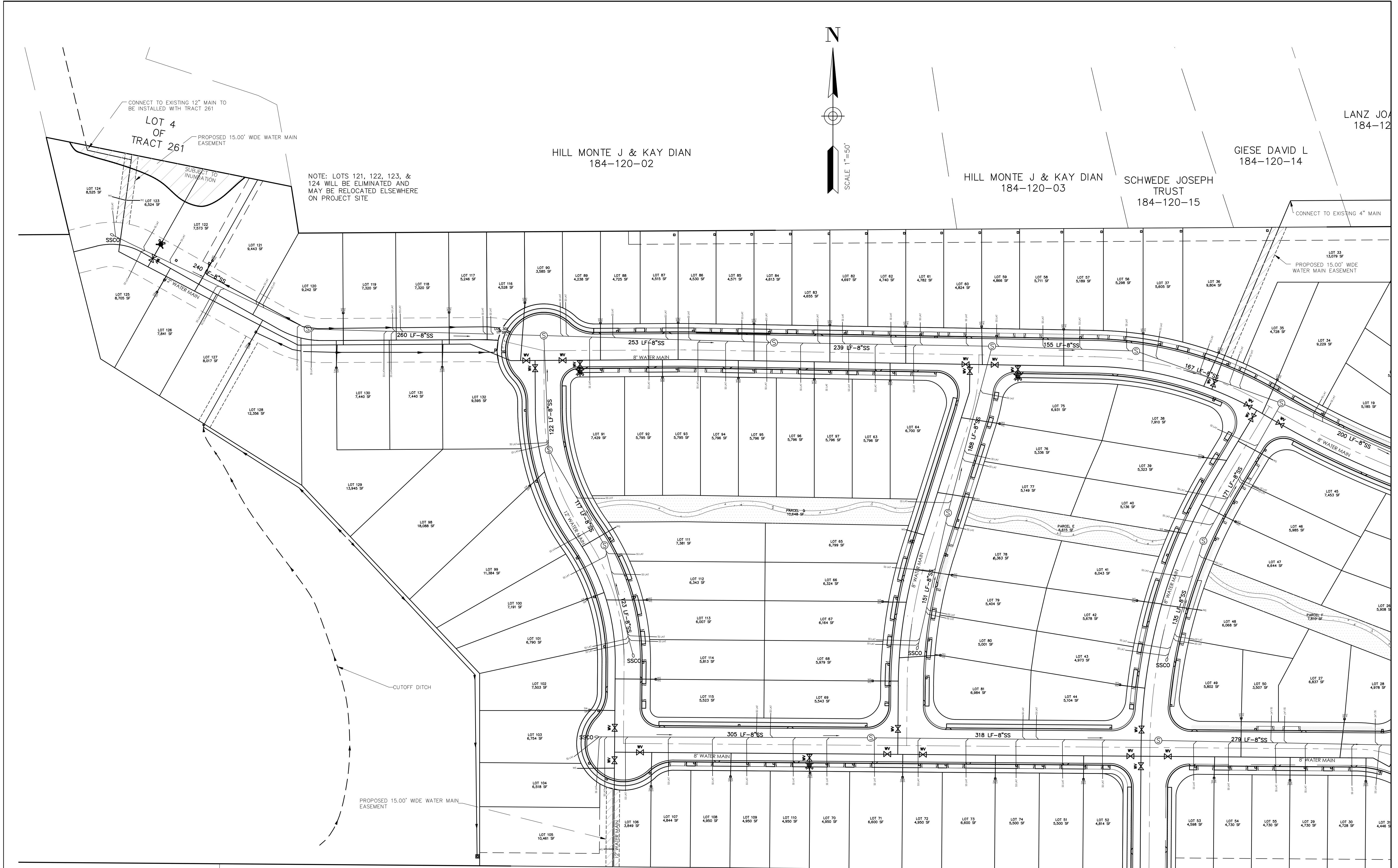

LACO  
EUREKA • UKIAH • SANTA ROSA • CHICO  
1-800-515-5054 www.lacoassociates.com

NO.	HISTORY / REVISION	BY	CHK.	DATE
1	ADDRESS COUNTY COMMENTS	X	X	8/28/2020

VESTING TENTATIVE MAP  
GUILLON INC. CONSTRUCTION  
3000 S STATE STREET, UKIAH, CA 95482  
UTILITIES

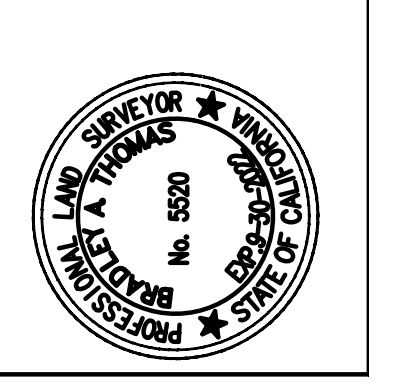

DRAWN	AR
CHECK	CCM
APPROVED	KD
DATE	August 31, 2022
JOB NUMBER	9100.06
DRAWING	8/10

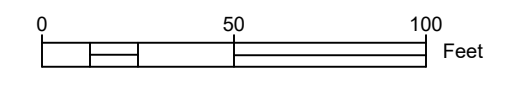



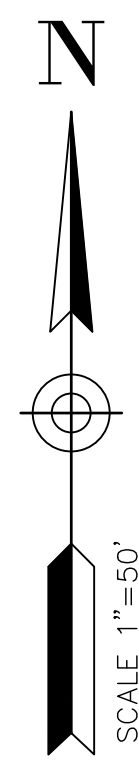
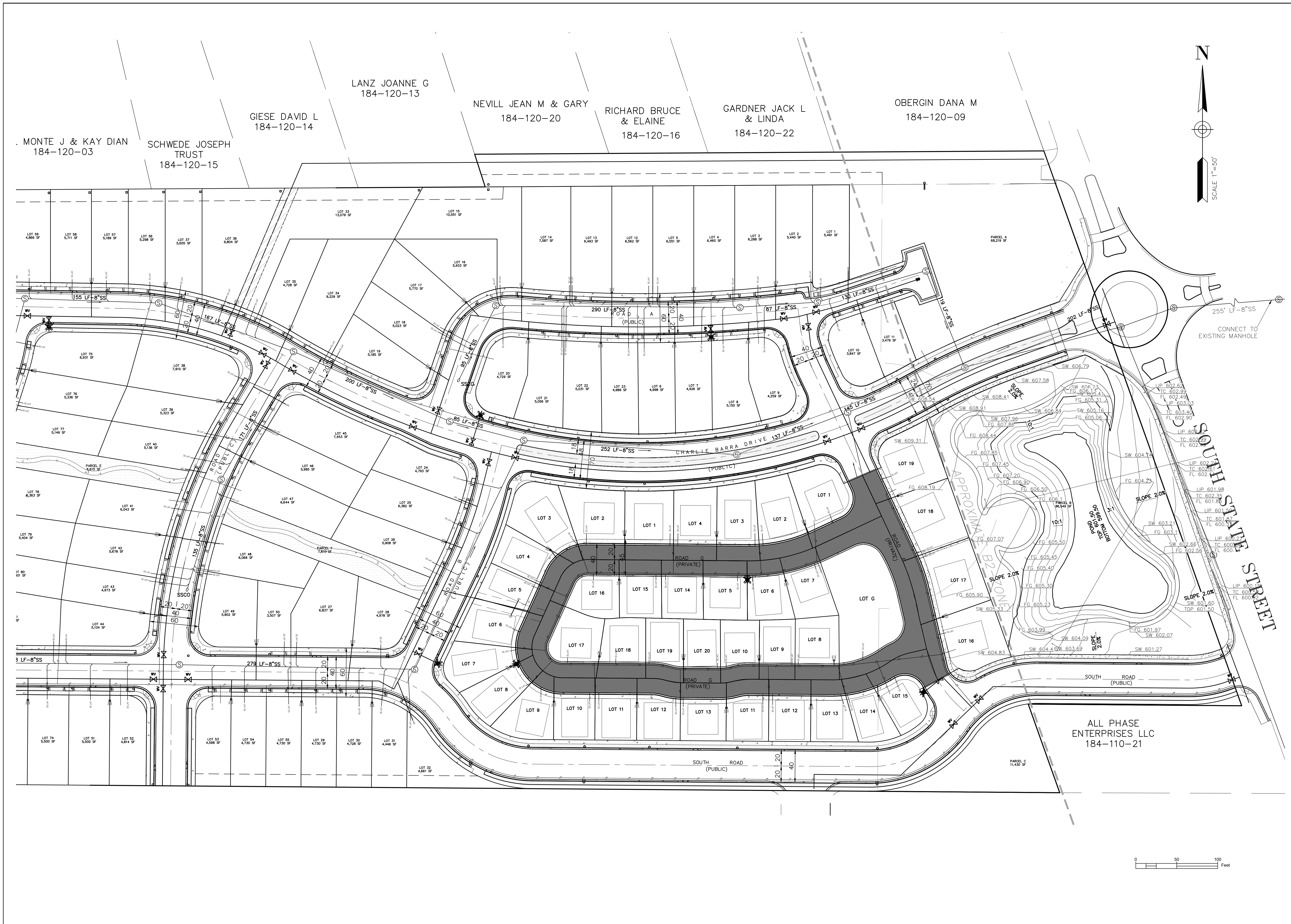

LACO  
 EUREKA • UKIAH • SANTA ROSA • CHICO  
 1-800-515-5054 www.lacoassociates.com

NO.	HISTORY / REVISION	BY / CHK.	DATE
1	ADDRESS COUNTY COMMENTS	X	8/28/2020

VESTING TENTATIVE MAP  
 GUILLON INC. CONSTRUCTION  
 3000 S STATE STREET, UKIAH, CA 95482

UTILITIES

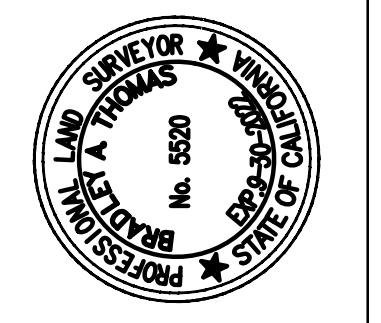

DRAWN	AR
CHECK	CCM
APPROVED	KD
DATE	August 31, 2022
JOB NUMBER	9100.06
DRAWING	9/10

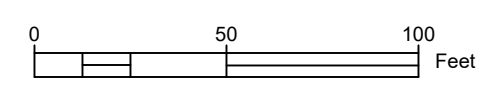



LACO  
 EUREKA • UKIAH • SANTA ROSA • CHICO  
 1-800-515-5054 www.lacocoassociates.com

NO.	HISTORY / REVISION	BY / CHK.	DATE
1	ADDRESS COUNTY COMMENTS	X	8/28/2020

VESTING TENTATIVE MAP  
 GUILLON INC. CONSTRUCTION  
 3000 S STATE STREET, UKIAH, CA 95482

TYPICAL SECTION DETAILS

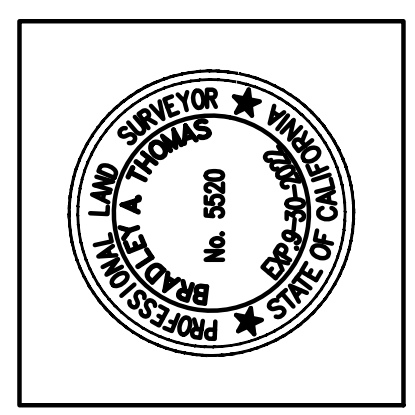

DRAWN	AR
CHECK	CCM
APPROVED	KD
DATE	August 31, 2022
JOB NUMBER	9100.06
DRAWING	10/10

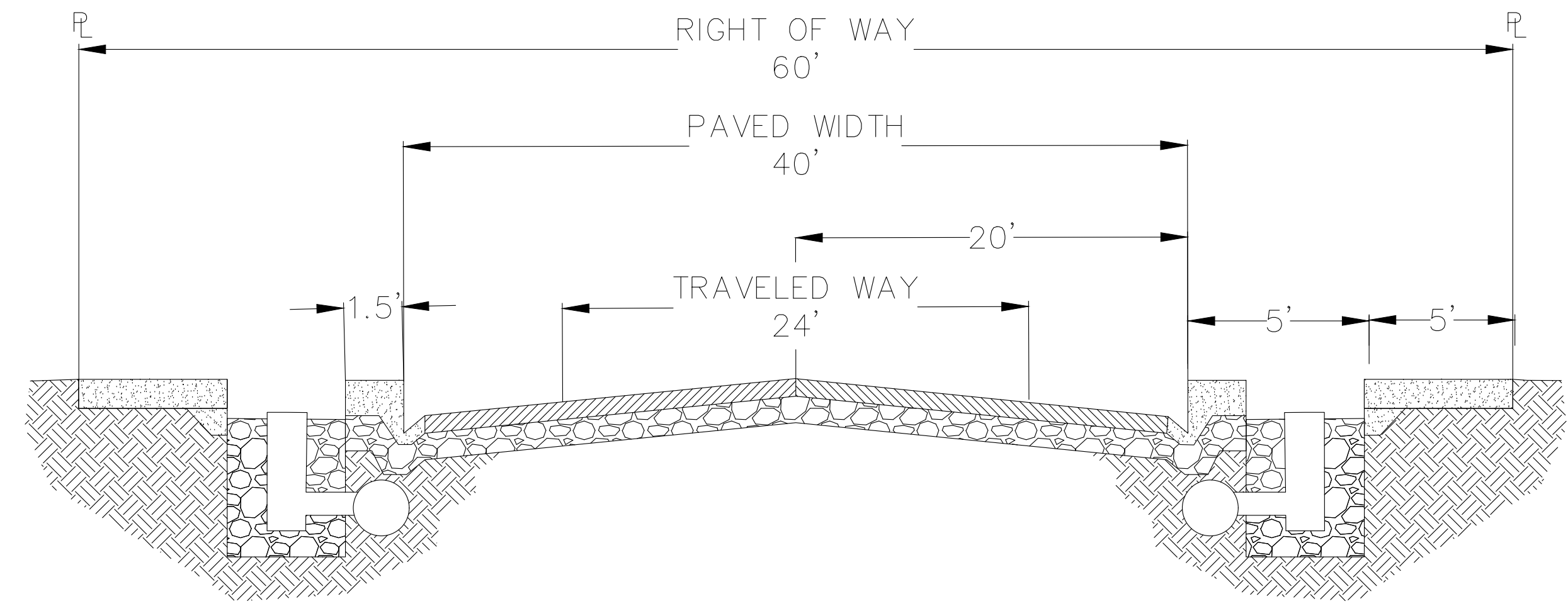

**1 TYPICAL ROAD SECTION DETAIL**  
 N.T.S.

ROAD A, B, C, D, & E, SOUTH ROAD,  
 CHARLIE BARRA DRIVE(27+50-38+50)

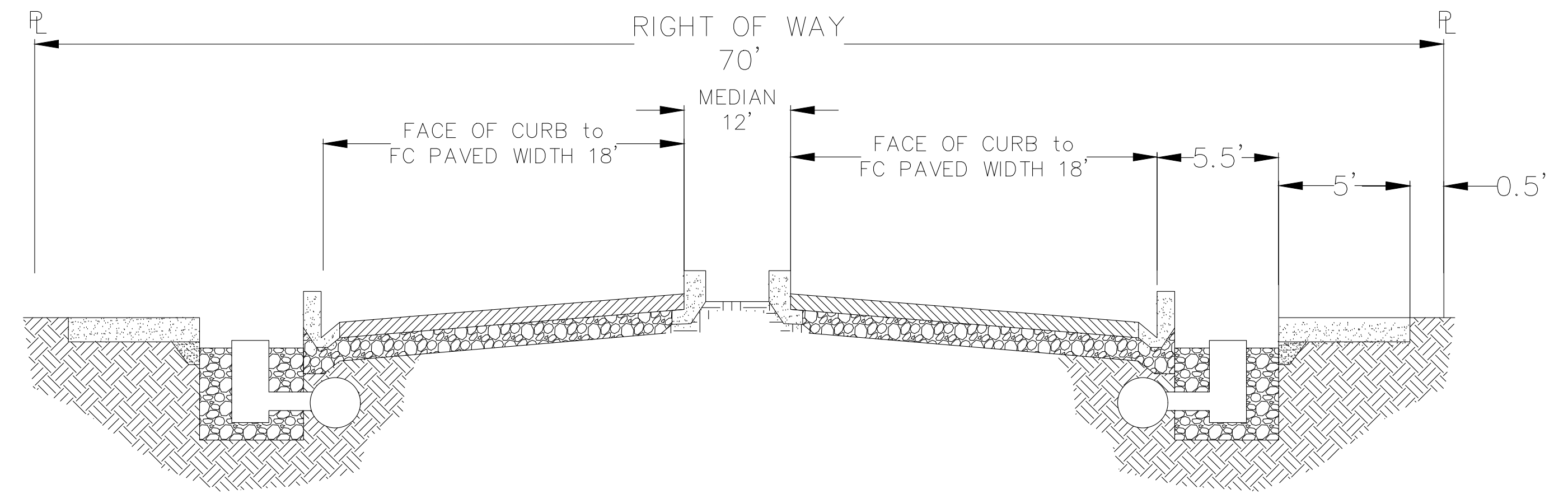

**2 LANDSCAPED ROAD SECTION DETAIL**  
 N.T.S.

CHARLIE BARRA DRIVE  
 STATION 20+00-27+50

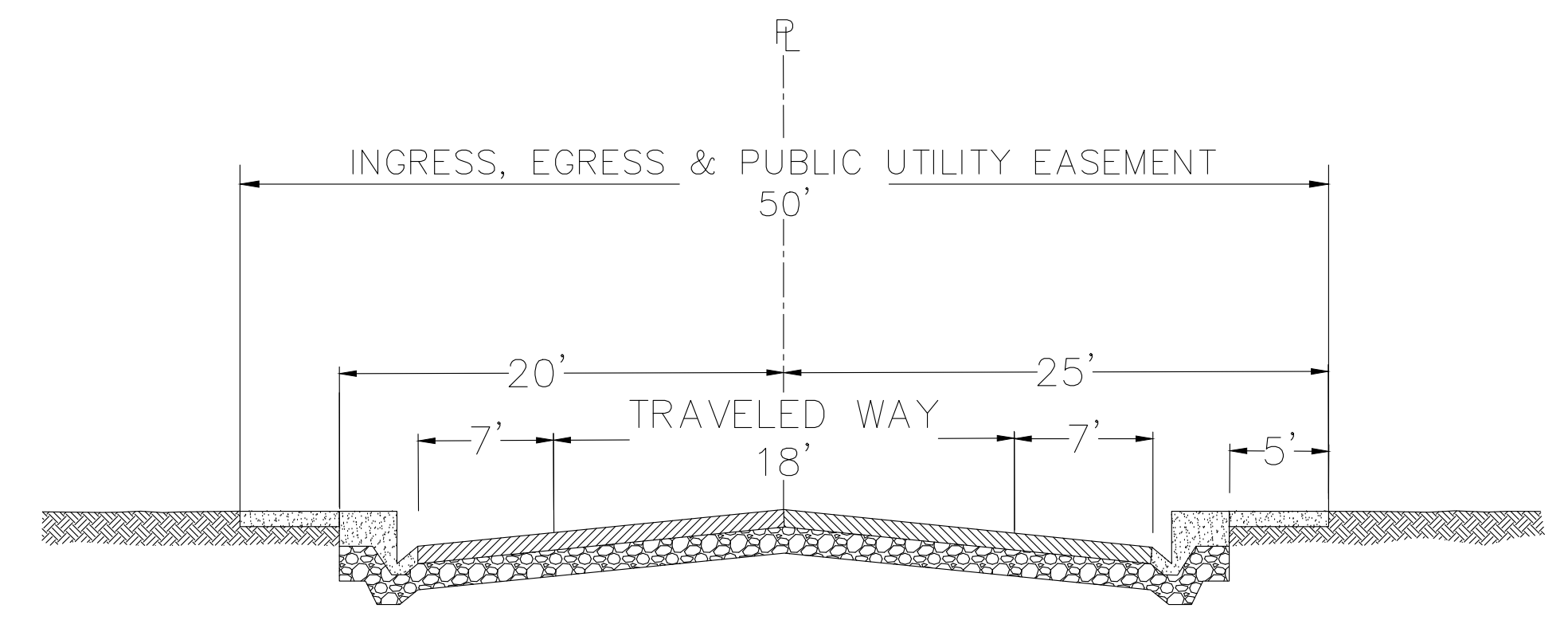

**3 REDUCED ROAD SECTION DETAIL**  
 N.T.S.

ROAD F & G

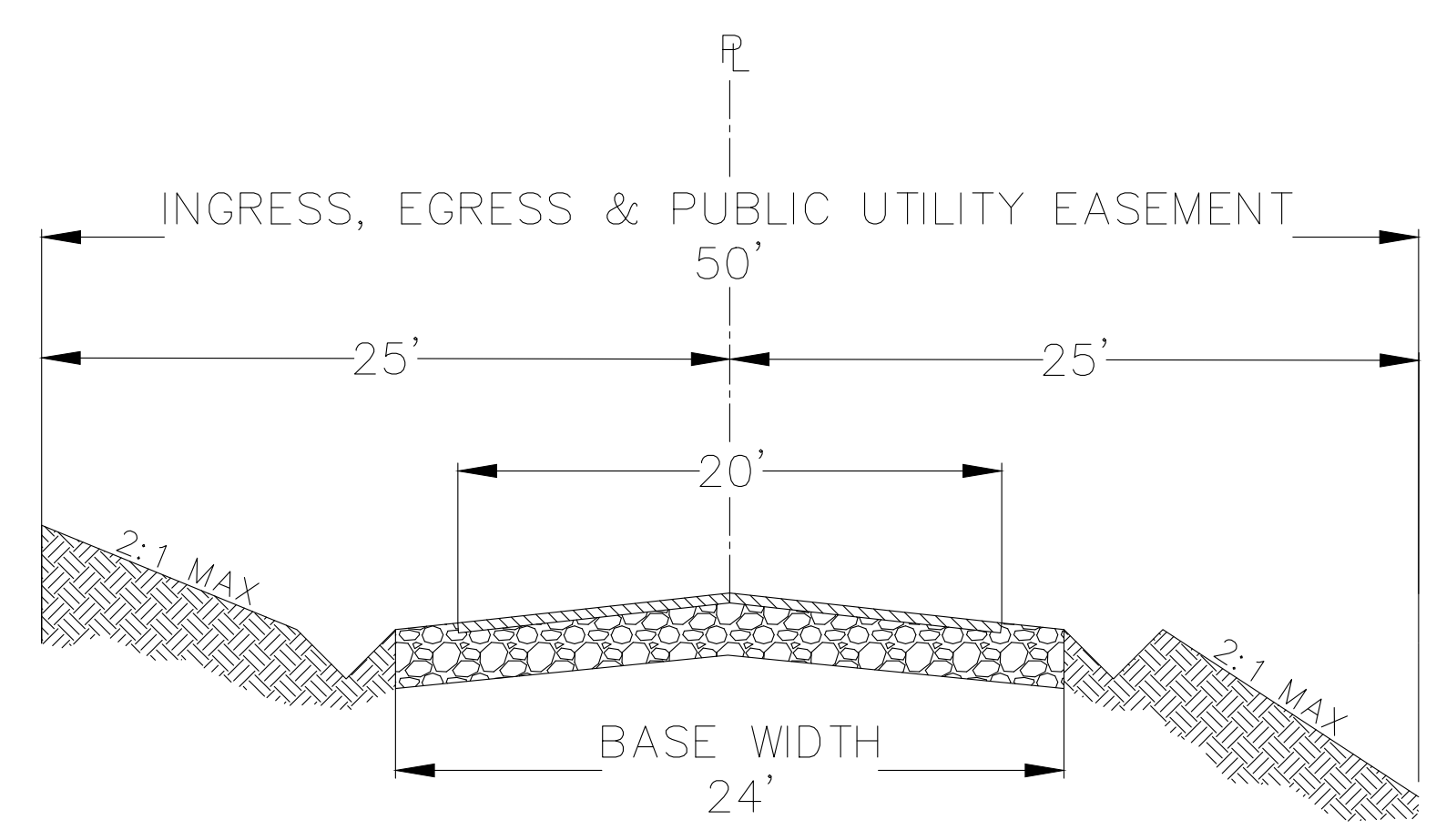

**4 PRIVATE ROAD SECTION DETAIL**  
 N.T.S.

COUNTRY LANE

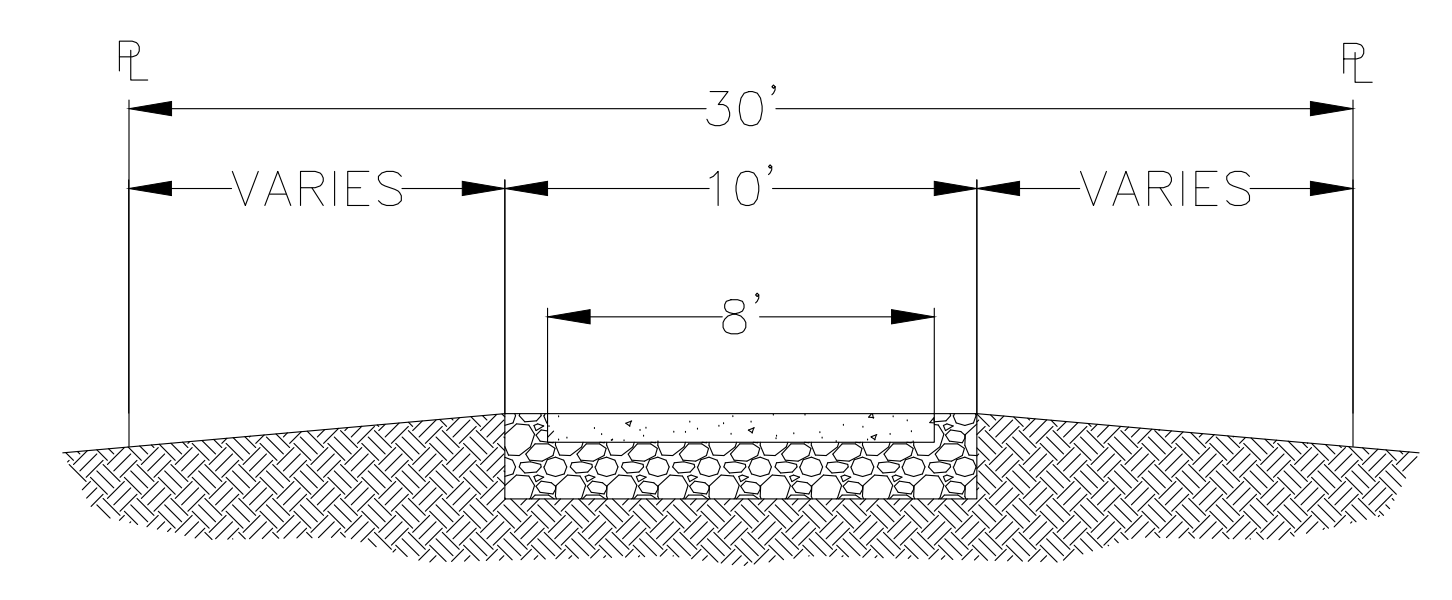

**5 PARKWAY PATH SECTION DETAIL**  
 N.T.S.

PARCELS D, E, F,  
 & NORTH SIDE OF LOT 17