

RESOLUTION NO. 26-

**RESOLUTION OF THE MENDOCINO COUNTY BOARD OF SUPERVISORS APPROVING
~~AND DISAPPROVING~~ CERTAIN EXCEPTIONS FROM THE COUNTY ROAD STANDARDS
FOR THE BELLA VISTA SUBDIVISION PROJECT**

WHEREAS, on February 3, 2026, the Board of Supervisors adopted Resolution No. 26-021, approving for the Bella Vista Subdivision Project (the "Project") an Amended Vesting Tentative Map (S_2020-0001) subject to Conditions of Approval, an Amended Mitigation Monitoring & Reporting Program, a Density Bonus and Reductions in Development Standards per State Density Bonus Law, Modified Preliminary Landscape Site Plan & Planting Plan, and an Inclusionary Housing Plan; and

WHEREAS, certain conditions of approval allow for the owner of the Project, Rancho Yokayo, L.P. ("Owner") and Guillion, Inc. ("Applicant") to apply for exceptions to the County's Road and Development Standards (the "Standards") pursuant to Tab H of said standards; and

WHEREAS, on behalf of the Owner and the Applicant, the engineering firm of Rolls, Anderson & Rolls ("RAR") submitted exception requests to the Mendocino County Department of Transportation ("DOT") for processing, seeking exception requests to (1) use high density corrugated polyethylene (HDPE) pipe for the storm drain system instead of reinforced concrete pipe ("RCP") and (2) Standard Plan A40A regarding curbs and gutters to install a rolled curb and gutter rather than squared curbs, attaching various other jurisdictions' standard construction details for rolled curbs, including that of Sonoma County and the City of Sacramento; and

WHEREAS, the closest standard for underground storm drains in the Standards is for culverts under residential and commercial driveways, as shown and discussed on Standard Plan pages A51A, A51B and A51C, which provides that culvert size and material are subject to the approval of the County; and

WHEREAS, Tab H of the Standards provides that requests for exceptions shall be acted upon as an element of the permit or request or approval at issue, or if a request for exception is related to a previous approval, it shall then be referred for action by the authority making the original approval, which in this case is the Board of Supervisors; and

WHEREAS, following RAR's submittal of the exception requests to DOT, DOT indicated in writing that it would deny the request to use HDPE pipe instead of RCP, and that it would support the rolled curb exception request, so long as the Sonoma County standard construction details were followed, which include rebar within the rolled curb; and

WHEREAS, based on the language in Tab H, the written responses by DOT are not final, but are to be referred to the Board of Supervisors for a final determination, with any approvals of requests for exceptions needing to be supported by findings as provided in paragraph H.6.B of Tab H; and

WHEREAS, by a letter dated March 21, 2026, the Applicant submitted additional information for the Board's review in support of their exception requests, including a request to use a rolled curb standard without rebar, and again seeking to use HDPE pipe for storm drains as opposed to RCP; and

WHEREAS, the Board of Supervisors has reviewed the exception requests made by the Owner and Applicant and the responses and rationales of DOT to the exception requests.

NOW, THEREFORE, BE IT RESOLVED, based on the whole of the record before it, that the Mendocino County Board of Supervisors finds and determines as follows:

1. The Board of Supervisors hereby grants the requested exception to Standard Plan A40A and approves the use of rolled curbs in the Project, using the specifications adopted by ~~Sanoma County~~the City of Sacramento (Curb & Gutter Type 1), which are attached hereto as Attachment A and incorporated herein by this reference. This exception is granted based on the following findings and determinations pursuant to Paragraph H.6.B of Tab H:
 - a. The design, material, method or work proposed is, for the purpose intended, equivalent to or superior to the Standards. The rolled curb and gutter will convey stormwater similar to a vertical curb and gutter.
 - b. The exception is consistent with the intent of the requirements of the Standards and does not constitute a grant of special privilege. Rolled curbs have been used in other residential subdivisions in unincorporated areas on both the north and south sides of the City of Ukiah and allowing it in this instance would not be considered a special privilege.
 - c. The exception will not result in increased adverse environmental impacts compared to the strict application of the requirements of the Standards. Construction techniques for rolled curbs and gutters can be efficient and reduce construction duration.
 - d. The granting of the exception will not be injurious or detrimental to the public health, safety, convenience and general welfare or injurious to other property in the vicinity of which said property is located. There is no evidence that installation of rolled curbs and gutters will be injurious or detrimental to the public health, safety, convenience or general welfare, or injurious to other property in the vicinity of the Project.

2. The Board of Supervisors hereby ~~denies~~approves the requested exception to use HDPE pipe for the Project's storm drain system,~~instead requiring the Project to install RCP for the storm drain system~~, based on the following findings and determinations pursuant to Paragraph H.6.B of Tab H:
 - a. The design, material, method or work proposed is, for the purpose intended, ~~not~~ equivalent to or superior to the Standards. ~~While HDPE and RCP share a predicted lifespan and are similarly resistant to erosion, concrete is fire resistant, making it more suitable for a fire-prone area such as Mendocino County~~HDPE offers at least an equivalent combination of longevity, cost-effectiveness and resilience compared to traditional RCP, including creating less chance of root intrusion and the ability to bend and move with the earth rather than snap or crack in an earthquake.
 - b. The exception is consistent with the intent of the requirements of the Standards and does not constitute a grant of special privilege. ~~The Standards contain an adopted standard in Section 64 for using HDPE pipe, other Northern California jurisdictions, including the City of Ukiah, allow for HDPE pipe and the County has approved HDPE in prior large residential subdivisions so the ability to use HDPE pipe does not constitute a grant of special privilege. Requiring RCP is consistent with DOT and the Road Commissioner's concerns about the susceptibility of HDPE to fire damage and stated intent to require RCP in storm drains given wildfire concerns. While no pattern for storm drain plans has been set since the 2017 wildfires, as no other major subdivision has been approved by the County since that time, the requirement to use RCP is consistent with the intent of the requirements of the Standards and does not constitute a grant~~

~~of special privilege.~~

- c. The exception will not result in increased adverse environmental impacts compared to the strict application of the requirements of the Standards. ~~While the use of HDPE is potentially more intensive during construction, it is determined not to outweigh the environmental impact of replacement in the event of wildfire~~ HDPE weighs about one-tenth the weight of RCP, which results in easier handling, smaller work crews, reduced heavy equipment requirements, improved safety, creating a lesser environmental impact from the Project due to such efficiencies.
- d. The granting of the exception will not be injurious or detrimental to the public health, safety, convenience and general welfare or injurious to other property in the vicinity of which said property is located. ~~because HDPE has more potential to be detrimental to the public because the increased chance of damage from wildfires, and potential cost of replacement to the County in such event~~ HDPE pipe will provide a number of efficiency benefits to the construction of the Project and will not impact property owners in the vicinity of the Project.

The foregoing Resolution introduced by Supervisor _____, seconded by Supervisor _____, and carried this _____ day of _____, 2026, by the following vote:

AYES:
NOES:
ABSENT:

WHEREUPON, the Chair declared said Resolution adopted and SO ORDERED.

ATTEST: DARCIE ANTLE
Clerk of the Board

BERNIE NORVELL, Chair
Mendocino County Board of Supervisors

Deputy

I hereby certify that according to the provisions of Government Code Section 25103, delivery of this document has been made.

APPROVED AS TO FORM:
KATHARINE L. ELLIOTT
Interim County Counsel

BY: DARCIE ANTLE
Clerk of the Board

Deputy

Attachment A

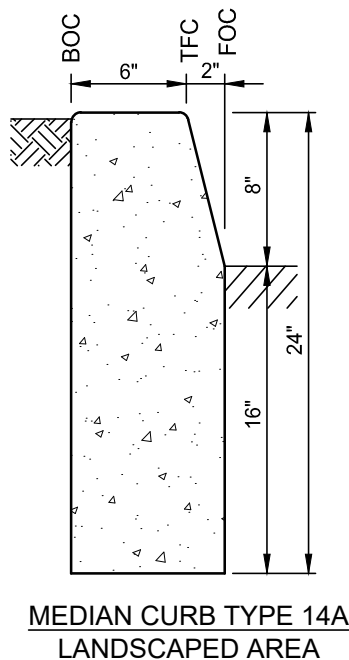
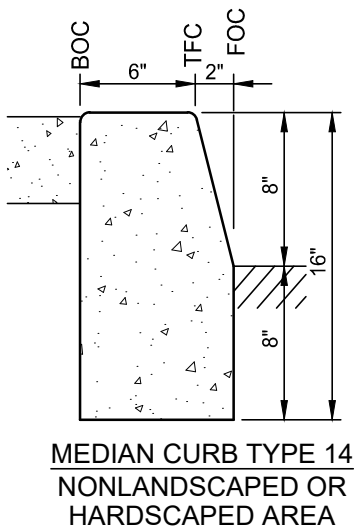
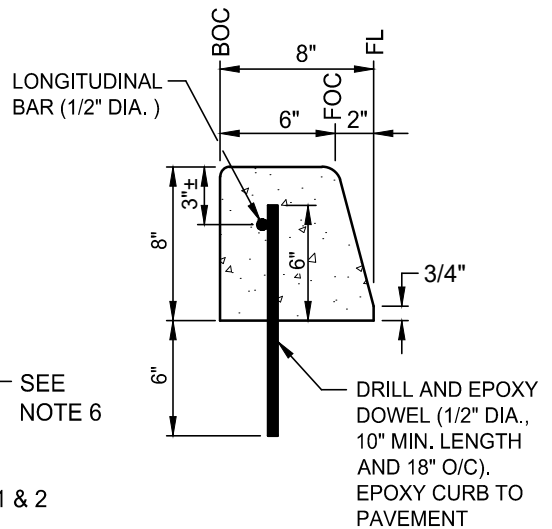
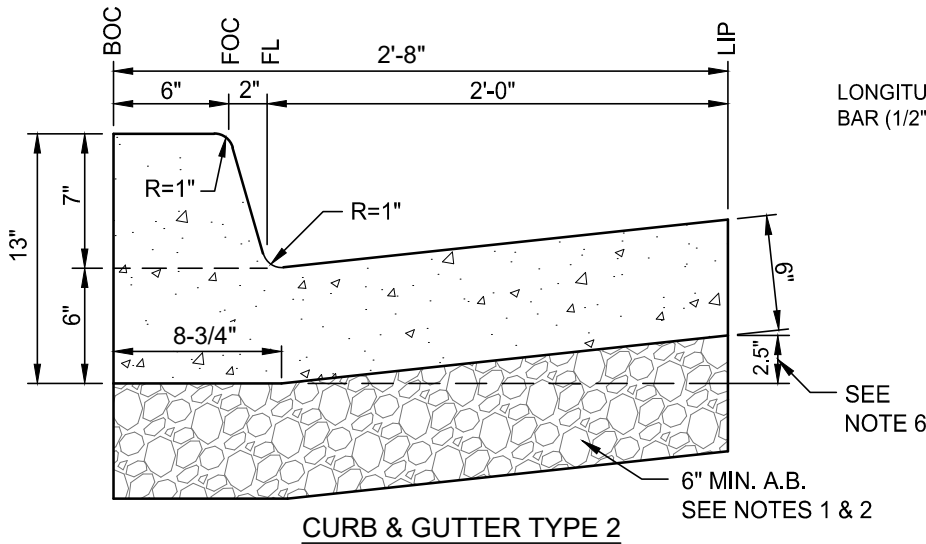
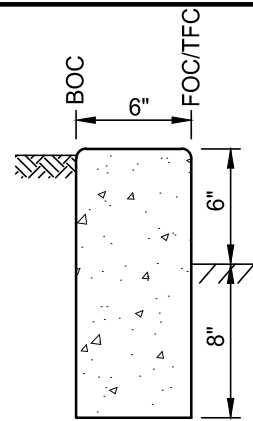
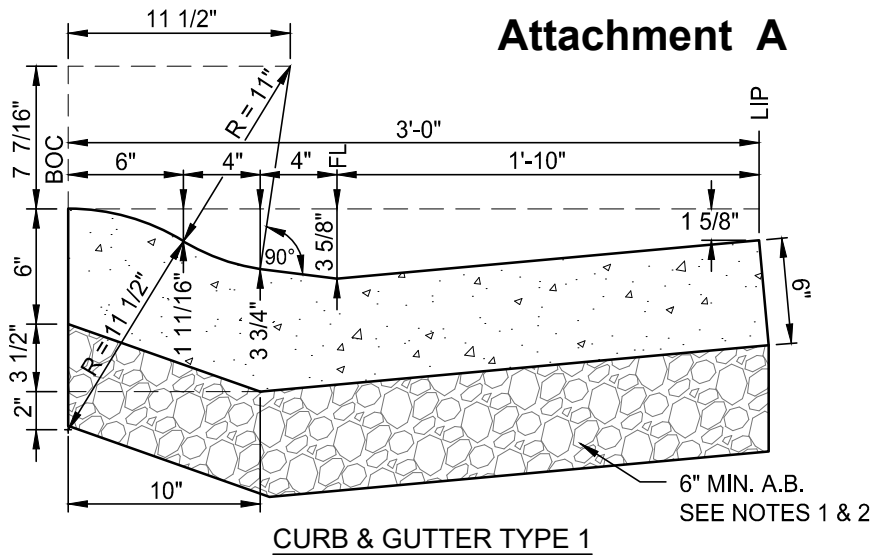

NOTES:

1. 12" MIN. A.B. SHALL BE PLACED IF SUBGRADE IS EXPANSIVE CLAY (R-VALUE LESS THAN 12).
2. TOP 6" OF SUBGRADE SHALL BE COMPACTED TO 95% MIN., UNLESS OTHERWISE APPROVED
3. 1/2" RADIUS ON EXPOSED EDGES.
4. ALL CONCRETE SHALL BE CLASS B.
5. ALL CONSTRUCTION & MATERIALS IN CONFORMANCE WITH SECTION 24 OF STD. SPECIFICATIONS.
6. ACROSS THE PEDESTRIAN ROUTE AT CURB RAMP LOCATIONS, THE GUTTER PAN SLOPE SHALL NOT EXCEED 1" OF RISE FOR EACH 2'-0" OF WIDTH.

ABBREVIATIONS:

FOC ... FACE OF CURB
BOC ... BACK OF CURB
FL FLOWLINE
TFC TOP FACE OF CURB

REV.	DATE	DESCRIPTION
△		
△		
△		

CITY OF SACRAMENTO
DEPARTMENT OF PUBLIC WORKS

**STANDARD CURB AND
GUTTER DETAILS**

APPROVED BY: *Nadel Kamel*
DATE: APRIL 2020 DWG. NO. T - 11